

THEORY OF MACHINES

Full Marks: 70

Time: 3 hours

Answer SIX questions including Q No. 1 which is compulsory  
The figures in the right hand margin indicate marks. Symbols carry usual meaning

Q1. Answer all questions.

[2-10]

1. a. Distinguish clearly, with suitable examples in each case, between the following
  - i. Fluid link and Flexible link
  - ii. Screw pairs and Spherical pairs
- b. Define the following terminology of cams.
  - i) base circle
  - ii) trace point
  - iii) pitch curve
  - iv) pressure angle
- c. Locate instantaneous centers for the following mechanism.

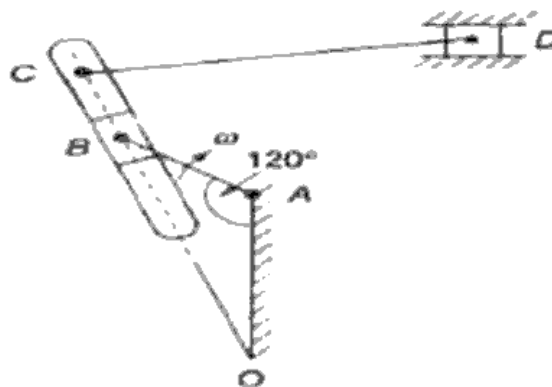

- d. Enumerate the inversions of Double slider crank chain.
- e. What are the limitations of Scott Russell mechanism?
- f. Define dedendum circle, line of action, module, arc of contact pertaining to gears.
- g. Define the following terminology of cams. i) base circle ii) trace point
  - iii) pitch curve
  - iv) pressure angle
- h. State the laws of (i) Solid friction (ii) Dynamic friction and (iii) Fluid friction
- i. State the function of a flywheel and mention how it differs from a governor.
- j. What are the effects of friction and of adding a central weight to the sleeve of a Watt governor?

2. In a slider-crank mechanism, the length of crank OA is 65 mm, and the length of connecting rod AB is 250mm. The C.G. of the connecting rod is 65 mm from the crank pin, and the crank rotates anti-clockwise with uniform motion of 3000 rpm. Determine the acceleration of the wrist pin B, and the acceleration of the centre of gravity of the connecting rod, when the crank makes an angle of 45° with the center line connecting O and B. Solve the problem using the Relative Velocity method.

3. a) How the pressure angle effects the follower motion? Explain by considering uniform motion, S.H.M and parabolic motion. 5

b) A cam rotating clockwise at a uniform speed of 200 r.p.m. is required to move an offset roller follower with a uniform and equal acceleration and retardation on both the outward and return strokes. The angle of ascent, the angle of dwell (between ascent and descent) and the angle of descent is  $120^\circ$ ,  $60^\circ$  and  $90^\circ$  respectively. The follower dwells for the rest of cam rotation. The least radius of the cam is 50 mm, the lift of the follower is 25 mm and the diameter of the roller is 10 mm. The line of stroke of the follower is offset by 20 mm from the axis of the cam. Draw the cam profile. 5

4. a) Prove that the center distance between two involute gear teeth, which are in mesh, is given by.

$$C = \frac{(R_1 + R_2)}{\cos \phi}$$

where  $R_1$  = Radius of the base circle of wheel 1,  $R_2$  = Radius of the base circle of wheel 2, and  $\phi$  = Pressure angle. 5

b) A pair of involute spur gears have 12 and 13 teeth respectively, module of 10 mm, addendum of 10 mm, and pressure angle of  $20^\circ$ . Check whether the gears have interference. 5

5.a. Determine the axial force required to engage a cone clutch transmitting 25 kW of power at 750 rpm. Average friction diameter of the cone is 400 mm, semi cone angle  $10^\circ$  and coefficient of friction 0.25. Also find the width of the friction cone. 5

b. An effort of 1500N is required to just move a certain body up an inclined plane of angle  $12^\circ$ , force acting parallel to the plane. If the angle of inclination is increased to  $15^\circ$ , then the effort required is 1720N. Find the weight of the body and the coefficient of friction. 5

6. Each of the rotating balls of a Hartung governor has a mass of 3.2 kg. The minimum and maximum radii of rotation of the governor balls are 11.4 cm and 14 cm respectively. Each spring has a stiffness of 87 N/cm and an initial compression of 5 cm. The mass of the sleeve is negligible. Determine the equilibrium speed of the governor at the mean position when the radius is 12.7 cm. Also, find the required spring stiffness and the initial compression to make the governor isochronous at this speed. 10

7. Two weights of 8 kg and 16 kg rotate in the same plane at radii of 1.5 and 2.25 m respectively. The radii of these weights are 600 apart. Find the position of the third weight of the magnitude of 12 kg in the same plane which can produce static balance of the system. 10

8. In an epicyclic gear train wheel A is keyed on the driving shaft, wheel B gears with A also with a fixed annular wheel C. Wheels B and D are fixed to the common spindle which is carried by an arm which can rotate about the axis of the wheel A and the wheel D gears with an annular wheel A and the wheel D gears with an annular wheel E which is keyed to the driven shaft. If E has 30 teeth, B has 36 and D has 20 teeth with same pitch find the velocity ratio of driving & driven shafts. 10

<http://www.odishastudy.com>

Whatsapp @ 9300930012

Send your old paper & get 10/-

अपने पुराने पेपर्स भेजे और 10 रुपये पायें,

Paytm or Google Pay से